



More sizes with extended range

Series 80-SC

Split Coupled Vertical In-Line Centrifugal Pump

B-115E

 **Bell & Gossett**
a xylem brand

B&G Series 80-SC Split-Coupled Vertical In-Line Centrifugal Pump

Applications

- Hydronic Heating and Cooling Systems
- Industrial Process
- General Service
- Pressure Boosting

Advantages

- Low Supply and Return Arrangement
- Space Saving Design
- Easy Mechanical Seal Maintenance
- Support Ring for Easy Installations

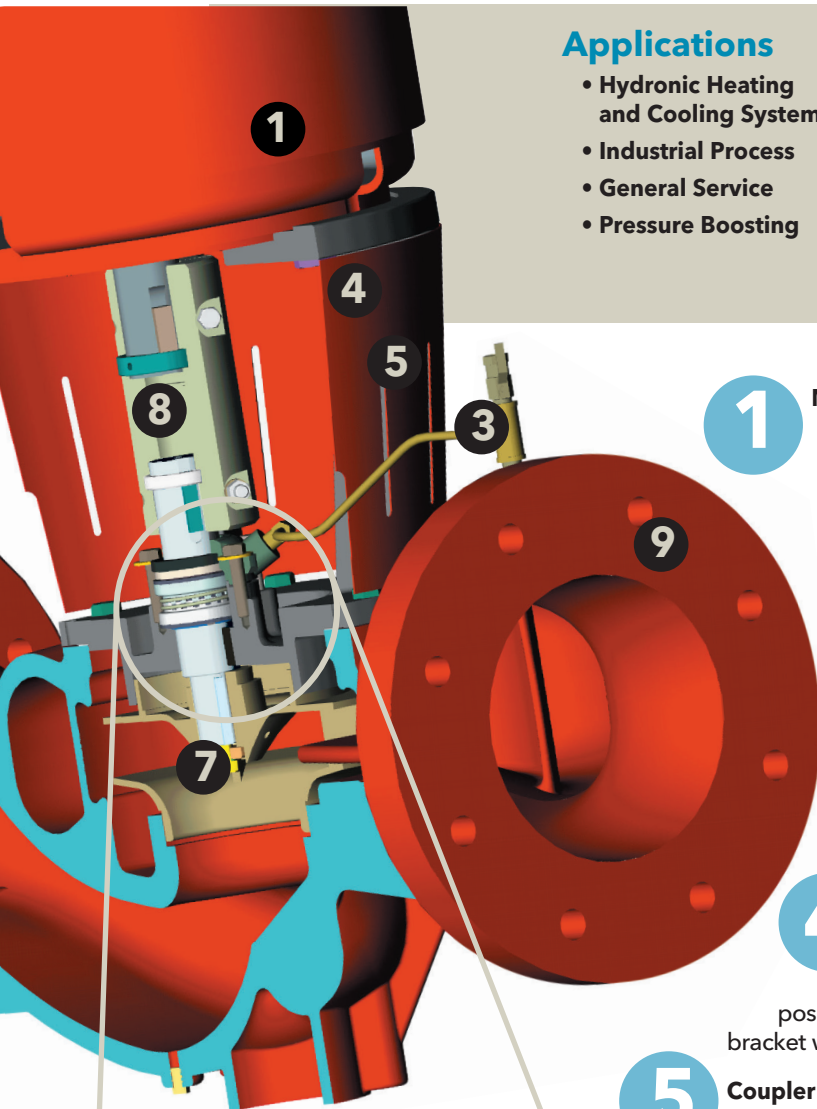

1 Motor
The NEMA Premium Efficient C-face motor is standard for this pump with an open drip-proof enclosure. This pump will also accept the vertical P-base motor or IEC motors that meet International Standards IEC 6034 as an option (except 12x12x13 and 14x14x14).

2 Mechanical Seal
The seal has a compact *Rotating Unitized Seal Head* design for easier seal replacement. The positive metal-to-metal drive system reduces the torsional stress on the bellows. The bellows are pressure supported without creases or folds, creating lower stress, and resulting in longer seal life.

3 External Flush
The external flush line has a manual valve to remove air from the seal chamber to ensure cooling liquid at the seal for fast initial start-up.

4 Motor Bracket
Brackets are designed for a wider access area for easier seal removal. The combination motor bracket/volute coverplate assures positive concentric alignment of the motor to the pump casing. The motor bracket will accept TC, HP, and IEC motors (except 12x12x13 and 14x14x14).

5 Coupler Guard
Conforms to ANSI and OSHA for safe operation.

Ease of Serviceability
6 The axially-split spacer coupling permits seal maintenance without disturbing the pump or motor. The seal can be removed between the gap in the pump and motor shaft when the coupler is removed.

7 Impeller
The 80-SC impeller is balanced to ANSI grade 6.3 and provides years of trouble free service.

8 Pump Shaft
The 416 stainless steel pump shaft provides high levels of corrosion resistance to the pumped fluid.

9 Volute
An Anti-Swirl vane below the impeller eye keeps NPSHr to a minimum. The 6" and larger pumps include a double volute to minimize radial loads for extended bearing and mechanical seal life. The volute includes a support ring on the bottom of the casing for installations adjacent to the floor (except 12x12x13 and 14x14x14).

10 Throttle Bushing
Antimony-impregnated carbon graphite throttle bushing for longer service life.

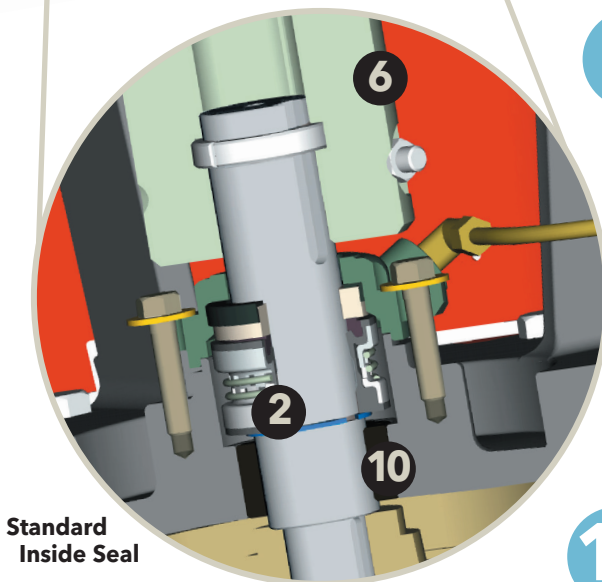

12x12x13 & 14x14x14 drawings not shown

Construction Materials

(For parts in contact with fluid pumped)

Description	Bronze Fitted Pump	All Iron Pump
Shaft	416SS Stainless Steel	416SS Stainless Steel
Volute	Cast Iron ASTM #A159 or Ductile Iron*	Cast Iron ASTM #A159 or Ductile Iron*
Impeller	Cast Bronze ASTM #B584	Cast Iron ASTM #A159
Impeller Key	Stainless Steel	Stainless Steel
Impeller Lock Washer	Stainless Steel	Stainless Steel
Impeller Capscrew	Stainless Steel	Stainless Steel
Volute Gasket	Cellulose Fiber	Cellulose Fiber
Throttle Bushing	Carbon Graphite	Carbon Graphite
Seal Assemblies		
• Standard Seal - Inside Flushed		
Bellows	EPR	EPR
Faces	Carbon-Ceramic	Carbon-Ceramic
Metal Parts	316 Stainless Steel	316 Stainless Steel
Spring	316 Stainless Steel	316 Stainless Steel
• Optional Seal - Inside Flushed		
Bellows	EPR	EPR
Faces	Carbon-Tungsten Carbide	Carbon-Tungsten Carbide
• Optional Seal - Outside Flushed		
O-Rings	EPR	EPR
Faces	Carbon-Ceramic	Carbon-Ceramic
Metal Parts	Stainless Steel	Stainless Steel
Gland Plate	Stainless Steel	Stainless Steel

*12x12x13 & 14x14x14 only

Standard pump construction is 175 psi working pressure with 125 ANSI flange drilling. Optional 250 psi working pressure with 250 ANSI flange drilling is available.

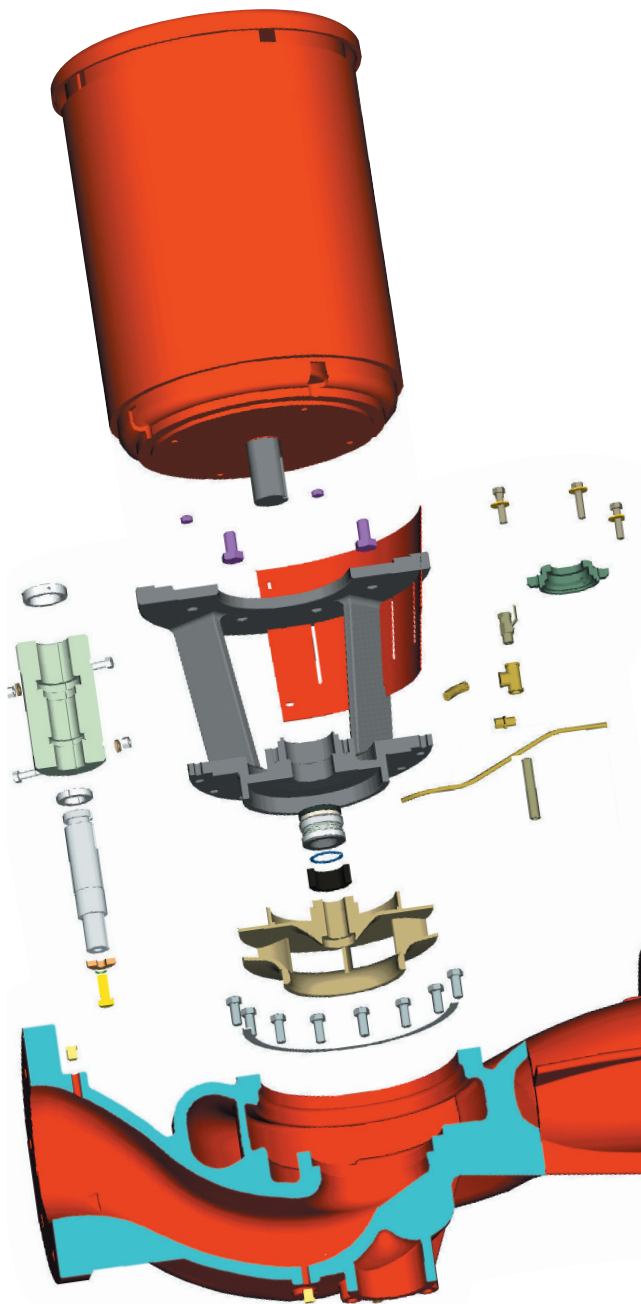

12x12x13 & 14x14x14 drawings not shown

Seal Selection Guide

A. Standard Seal - Inside with flush line.

EPR/Carbon-Ceramic pH limitations 7-9; Temperature Range -20° to +250°F.* Maximum pressure is 175 psi.

B. Optional Seal - Inside with flush line.

EPR/Carbon-Tungsten Carbide pH limitations 7-11; Temperature Range -20° to +250°F.* For use on open or closed clear water systems. Maximum pressure is 250 psi.

C. Optional Seal - Outside with flush line.

EPR/Carbon-Ceramic Type "8B2"; pH limitations 7-9; Temperature Range -20° to +250°F.* For use on closed or open systems where the pressure requirements exceed the limitations of the standard seal or an alternate seal design is desired. Maximum pressure is 250 psi.

* For operating conditions above 250°F and no greater than 300°F a cooled flush is required. On closed systems cooling is accomplished by inserting the optional heat exchanger kit in the flush line to cool the seal flushing fluid.

Flush line filters and sediment separators are available on request.

Optional Outside Seal

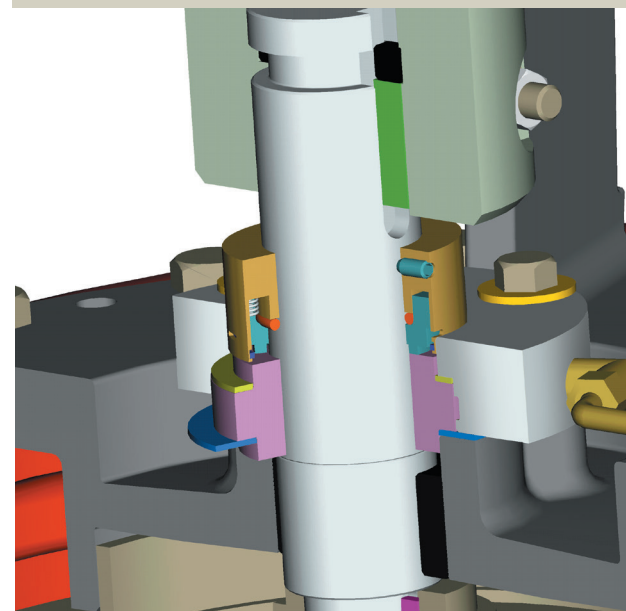

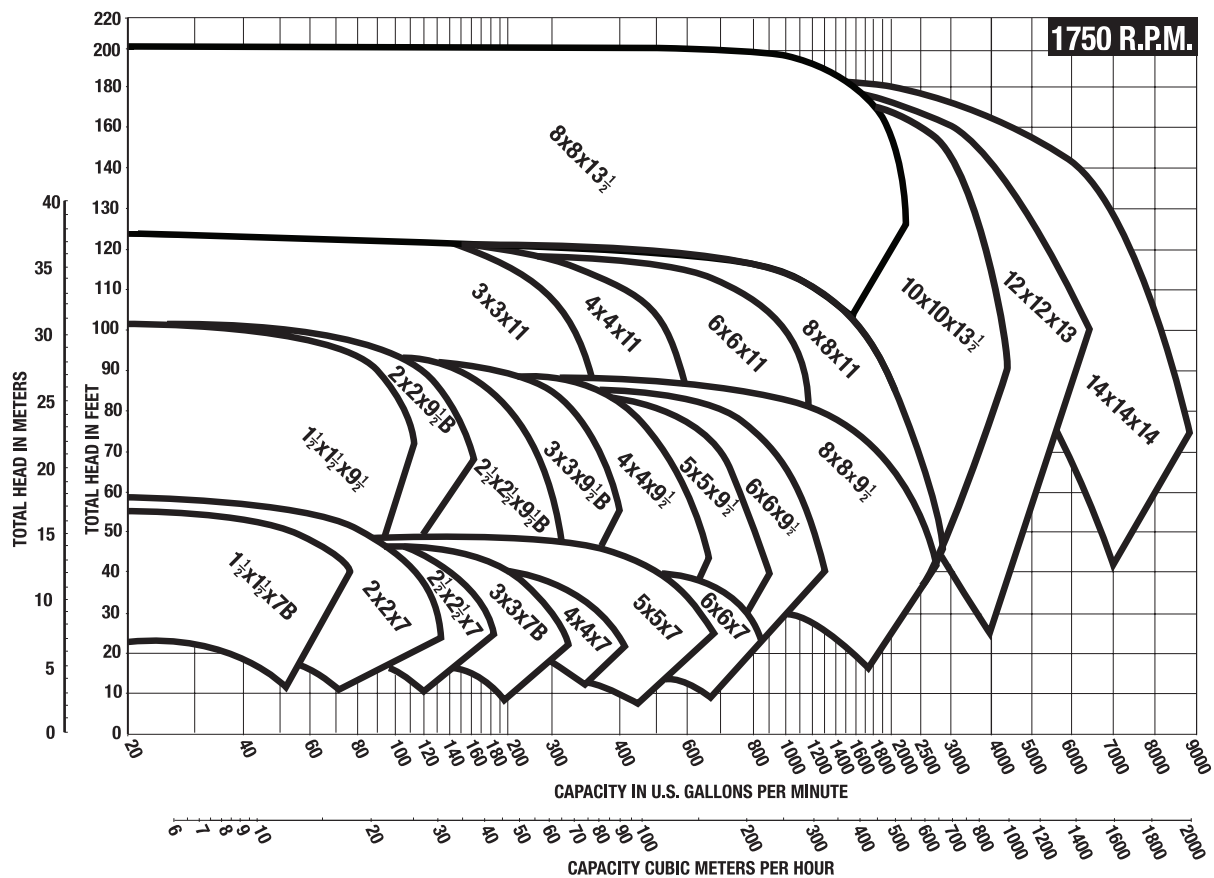

Engineering Specifications

Furnish and install pumps with capacities as shown on plans. Pumps shall be split-coupled in-line, single-stage design, for installation in a vertical position motor up, capable of being serviced without disturbing piping connections (except 12x12x13 and 14x14x14).

Pump volute shall be of Class 30 cast iron or ductile iron. It shall be designed with a base ring matching an ANSI 125# or 250# flange for pump support (except 12x12x13 and 14x14x14).

Optional factory fabricated pump base stanchions to support 10, 12 & 14" size pumps should be supplied separately.

The impeller shall be of cast bronze, enclosed type, balanced to Hydraulic Institute Standards (ANSI/HI 9.6.4.5-2000, figure 9.6.4.15B). The allowable residual imbalance conforms to ANSI grade 6.3, keyed to the stainless steel shaft and locked. The pump shaft shall be guided by a carbon graphite lower throttle bushing.

The combination motor bracket and volute coverplate shall be properly designed unit to ensure concentric alignment of the motor to the pump casing.

The liquid cavity shall have a tapped flush line with manual valve to remove air from the seal chamber for fast initial start-up.

The mechanical seal shall have a compact Rotating Unitized Seal Head design with EPR elastomer bellows and a positive metal to-metal drive system to reduce the torsional stress on the bellows.

Optional mechanical seal shall be stainless steel outside multi-spring balanced type with EPR (optional Viton) secondary seal.

The bellows will be pressure supported without creases or folds for long life.

The spacer coupling shall be of high tensile aluminum, split to allow the servicing of the seal without disturbing the pump or motor.

The motor bracket shall contain a carbon steel coupler guard conforming to both ANSI B15.1-2000 and OSHA 1910.219 standards for safety.

(Optional) The seal flush line shall be fitted with a factory installed 50 micron cartridge filter (cyclone separator when pump differential pressure exceeds 30 psig).

Pumps shall be rated for continuous operation at a minimum of 175 psi working pressure (optional 250 psi) and 250°F.

The volute shall have gauge tapings at the suction, and discharge nozzles and vent and drain tapings at the top and bottom.

Motor shall be NEMA Premium Efficient (NEMA MG-1 Table 12-12; 1 HP and up; three phase) complying with NEMA or IEC specifications (except 12x12x13 and 14x14x14) and shall be the size, voltage and enclosure called for on the plans. It shall have heavy-duty grease-lubricated ball bearings, completely adequate for the maximum load for which the pump is designed.

Each pump shall be hydrostatically tested at the factory per Hydraulic Institute standards. It shall then be thoroughly cleaned and painted with at least one coat of high-grade machinery enamel prior to shipment.

Pumps shall be Series 80-SC as manufactured by Bell & Gossett.



xylem
Let's Solve Water

Xylem Inc.
8200 N. Austin Avenue
Morton Grove, Illinois 60053
Phone: (847) 966-3700
Fax: (847) 965-8379
www.bellgossett.com

Bell & Gossett is a trademark of Xylem Inc. or one of its subsidiaries.
© 2013 Xylem Inc. B-115E June 2011